

Temporary Run Station with Tubular Key Lock, E-Stop, Engraved Push Buttons with Up/Down Arrows PL05MT-TUBKEY

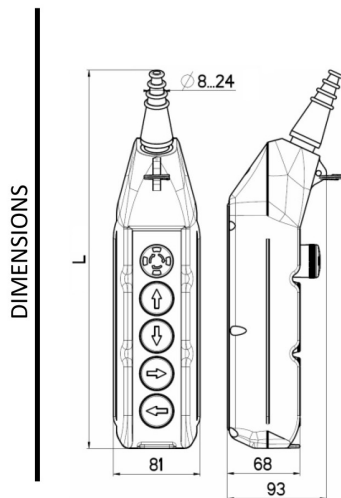

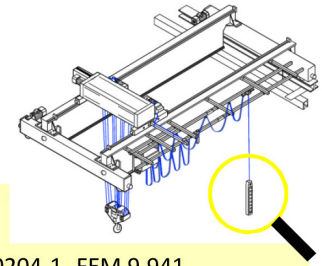

Characteristics:

- Bi-directional, mechanically interlocked
- IP 65 double insulation IEC/EN60529
- Laser engraved symbols comply with EN60204-1, FEM 9.941
- Shock proof and heat resistant



PUSH BUTTON TYPE – CONTACT TYPE COUPLED							
			(*) two speed contact block				

Temporary Run Station with Tubular Key Lock, E-Stop, Engraved Push Buttons with Up/Down Arrows PL05MT-TUBKEY

General characteristics		P02 – P03 – HP03 – PLN – PLBN – TLP									DC30	
In conformity to standards		IEC / EN60947-5-1									IEC / EN60947-3	
Material		P02	P03	HP03	PL	PLB	TLP					ABS
		PP	ABS	ABS	ABS	ABS	PP					
Material group		II									II	
Pollution class		3									3	
Climate temperature	operating	-25°C + 70°C									-25°C + 70°C	
	storage	-30°C + 70°C									-30°C + 70°C	
Climate resistance	IEC68 part 2-3	hot damp									hot damp	
	IEC68 part 2-30	unsettled hot damp									unsettled hot damp	
Cable entry		<ul style="list-style-type: none"> ▪ P02 – P03: rubber cable sleeve Ø7...18mm ▪ PL – PLB: rubber cable sleeve Ø9...24mm ▪ HP03: spiral cable gland M20 – TLP: cable gland M20 									cable gland M25	
Electrical characteristics contact blocks		P02 – P03 – HP03 – PLN – PLBN – TLP									DC30	
Markings												
Rated insulation voltage [Ui]		690V									500V	
Rated thermal current [Ith]		16A									25A	
Rated impulse withstand voltage [Uimp]		4kV									4kV	
Frequency		50Hz – 50/60 Hz type PCW (HP03-TLP)									50Hz	
Rated operating current [Ie]												
AC-15 alternate current		(V)	24	60	110	240	400	440	500	690		
	type: PL004.. P02/P03/DC30 e-stop/PLN/PLBN	(A)	16	12	8	6	4	3.5	3	1	-	
	type: PCW.. HP03-TLP	(A)	10	8	6	5	4	4	4	2	-	
DC-13 direct current		(V)	24	48	60	110	220	250				
	type: PL004.. P02/P03/DC30 e-stop/PL/PLBN	(A)	2	1.2	0.85	0.4	0.25	-				
	type: PCW.. HP03-TLP	(A)	2	2	1	0.4	-	0.4				
AC-3 alternate current	1phase-2poles 230V-400V	-									2.2kW	
	3phase-3poles 230V-400V	-									3kW	
Conditional short circuit withstand current		1000A									1000A	
Fuse rating		gG 10A - 500V									aM 12A - 500V	
Contact insulation resistance		≤ 25mΩ									-	
Switching mechanism	type: PL004.. P02/P03/DC30 e-stop/PLN/PLBN	slow break double gap contacts single pad									slow break double gap contacts single pad	
	type: PCW.. HP03-TLP	slow break double gap contacts three pads										
Positive operation		NC contact block 									-	
Terminal type	type: PL004.. P02/P03/DC30 e-stop/PLN/PLBN	M3.5 screw									M3.5 screw	
	type: PCW.. HP03-TLP	spring cage terminal										
Terminal capacity	type: PL004.. P02/P03/DC30 e-stop/PLN/PLBN	No. 1 or 2 flexible and solid conductor min 1 max 2.5 mm ²									No. 1 or 2 flexible and solid conductor min 1 max 2.5 mm ²	
	type: PCW.. HP03-TLP	No. 1 or 2 flexible and solid conductor min 0.5 max 2.5 mm ²										
UL508 characteristics												
General use		600V ac									16A	-
Designation code (HD) Heavy Duty		A600-Q600									-	

Temporary Run Station with Tubular Key Lock, E-Stop, Engraved Push Buttons with Up/Down Arrows PL05MT-TUBKEY

